

Step one: Installation of the handle bar

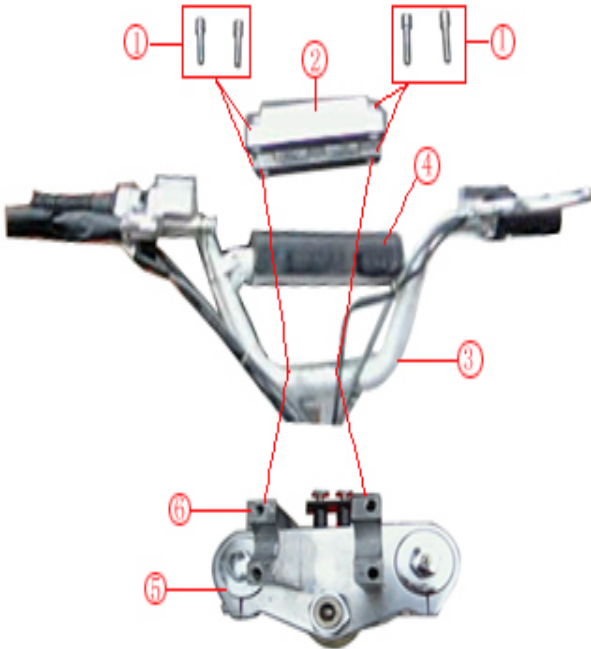

Name	Quantity	Standard	Remark
Bolt	4	M8 × 25	In the accessory case
Handle bar clip	1		In the accessory case
Handle bar	1		In the packing chest
Protector	1		On the bike
Upper joint plate, steering stem	1		On the bike
Clip seat, handle bar	2		On the bike

Instruction for the installation:

1. Take out from the accessory case, and then fix on with and .

Step two: Installation of the front face plate

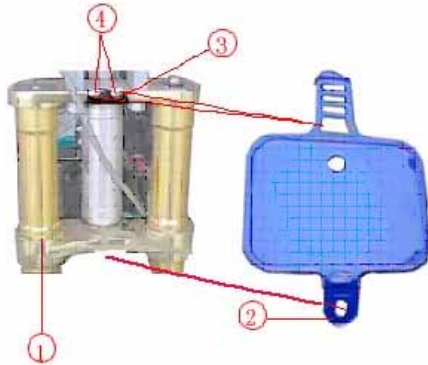

Name	Quantity	Standard	Remark
Steering stem	1		
Front face plate	1		In the accessory case
Top bracket, front face plate	1		On the bike
Bolt	2	M6 × 25	On the bike

Instruction for the installation:

1. Take off [] and [] from [] .
2. Fix the upper side of [] on [] with [] and [] .

Step three: Installation of the front fender

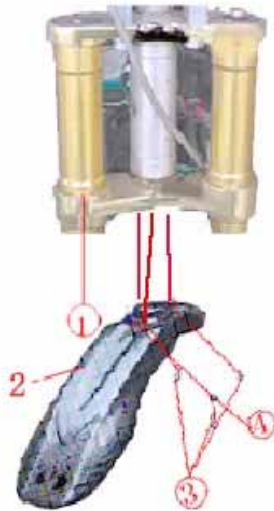

Name	Quantity	Standard	Remark
Lower joint plate	1		
Front fender	1		In the packing chest
Bolt	3	M6 × 16	In the accessory case
Bush	1		In the accessory case

Instruction for the installation:

1. Take out 、 from the accessory case;
2. Fix into the install hole of with and .

Step four: Installation of the footrest

Name	Quantity	Standard	Remark
Install hole, footrest	4		
Footrest	1		In the packing chest
Bolt	2	M8 × 25	In the accessory case
Bolt	2	M8 × 40	In the accessory case



Instruction for the installation:

Take out and from the accessory case, and then fix on
with and .

Step five: Installation of the starting arm& brake arm

Name	Quantity	Standard	Remark
Bush	1		In the accessory case
Bolt	1	M10 × 75	In the accessory case
Brake arm	1		In the packing chest
Axle, brake arm	1		
Starting arm	1		In the packing chest
Bolt	1	M6 × 20	In the accessory case
Installing axle, starting arm	1		On the bike

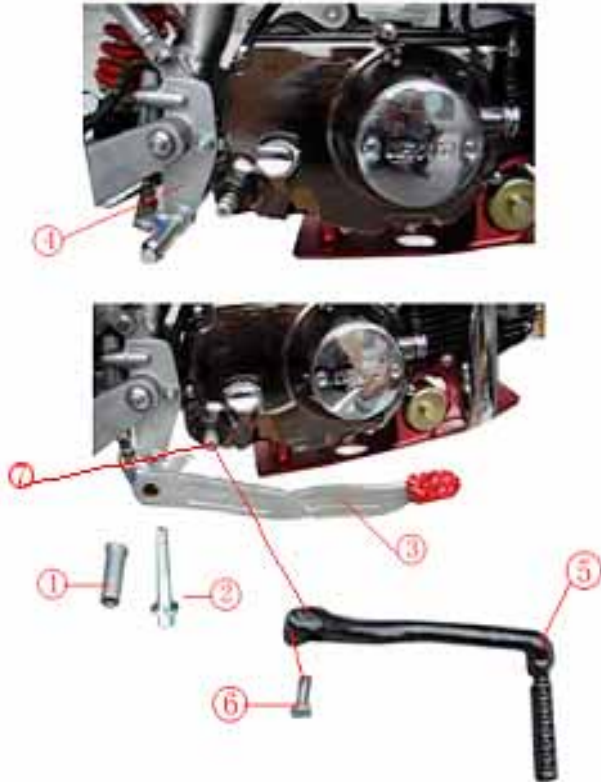

Instruction for the installation:

1. Take out 、 、 from the accessory case, fixing in with and ;
2. Fix in with .

Step six: Installation of the gear shifter

Name	Quantity	Standard	Remark
Axle, gear shifter	1		On the bike
Gear shifter	1		In the accessory case
Bolt	1	M6 × 25	In the accessory case



Instruction for the installation:

Take out and from the accessory case, then fix on
with .

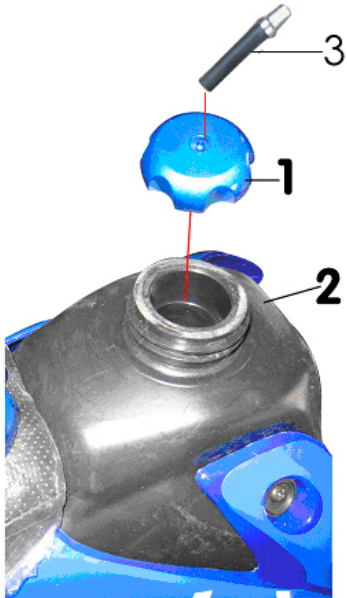

Step seven: Fix the fuel cap

Name	Quantity	Standard	Remarks
Fuel cap	1		In the accessory case
oil tank	1		On the bike
Pipe	1		In the accessory case

Instruction for the installation:

1. Take out [] from the accessory case , then tighten [] on [] .
2. Take out [] from the accessory case, and then screw down [] on [] .

Step eight: Fix the battery

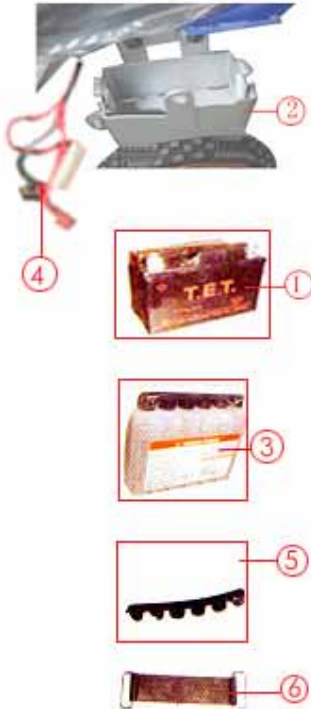

Name	Quantity	specification	Remark
Battery	1		In the accessory case
Battery box	1		On the bike
Electrolyte	1		In the accessory case
Battery cable	1		
Rubber plug	1		In the accessory case
Bundling band	1		In the accessory case

Instruction for the installation:

1. Put into , and fasten it with .
2. Put into , connect on ;
3. Then fix on with .

Attention:

The battery includes positive and negative lead, the battery cable includes red cable and green cable. Please be noted that the red cable should be connected with the positive lead, while green cable with negative lead when connecting.