

RKM-200E6

Instruction for the installation

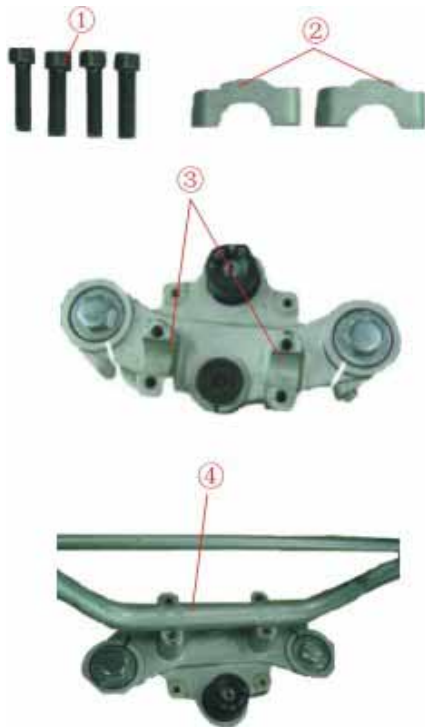

Step one: Handrail assembly

NO	Part Name	Spec.	Quantity	Memo.
①	Bolt, hexagon	M8×30	4	In accessory bag
②	Clip, handlebar		2	In accessory bag
③	Clip, upper connecting plate		1	On motorcycle
④	Handlebar		1	On motorcycle

1. Fix ① in the hole of ②;
2. Put ④ in ③, make sure their veins are in place;
3. Fix the combination of ① and ② on ④;
4. Screw ①.

Step two:Left handlebar switch assembly

NO	Part Name	Spec.	Quantity	Memo.
①	Handlebar		1	On motorcycle
②	Left handle-bar switch		1	On motorcycle

- 1、 Loosen the screw of ②,fix ② on ①;
- 2、 Tighten the screw of ②



Step three:Left lever assembly

NO	Part Name	Spec.	Quantity	Memo.
①	Left lever		1	On motorcycle
②	Handlebar		1	On motorcycle

- 1、 Loosen the screw of ①,fix ① on ②;
- 2、 Tighten the screw of ①



Step four:Meter and headlight assembly

NO	Part Name	Spec.	Quantity	Memo.
①	Bolt	M6×16	3	In accessory bag
②	Bolt	M6×25	2	In accessory bag
③	Bracket, headlight		1	On motorcycle
④	Meter and headlight assy.		1	On motorcycle
⑤	Bush		2	In accessory bag
⑥	Upper connecting plate			On motorcycle
⑦	Cover, headlight		1	On front part of tray

Step five:Rear shock absorber assembly

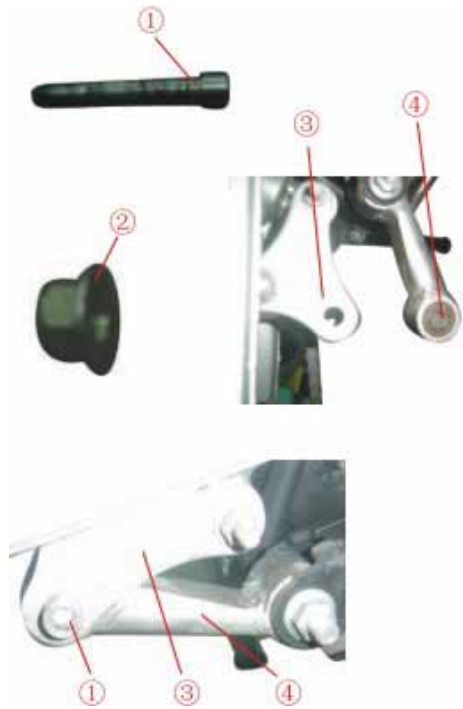

NO	Part Name	Spec.	Quantity	Memo.
①	Bolt, hexagon	M10×70	1	In accessory bag
②	Self-locking bolt	M10	1	In accessory bag
③	Connecting plate		1	On motorcycle
④	Swing arm		1	On motorcycle

- 1、Fix ④ inside of ③;
- 2、Insert ① through ③ and ④,
screw ② and tighten it .

Step six:Front fender assembly



NO	Part Name	Spec.	Quantity	Memo.
①	Nut	GB/T6177 M6	3	In accessory bag
②	Bolt	GB/T5787 M6×30	3	In accessory bag
③	Bracket, reflector		1	On motorcycle
④	Rubber		3	In accessory bag
⑤	Front fender		1	On rear wheel
⑥	Bush		3	In accessory bag
⑦	Front fork		1	On motorcycle

Step seven: Front wheel assembly

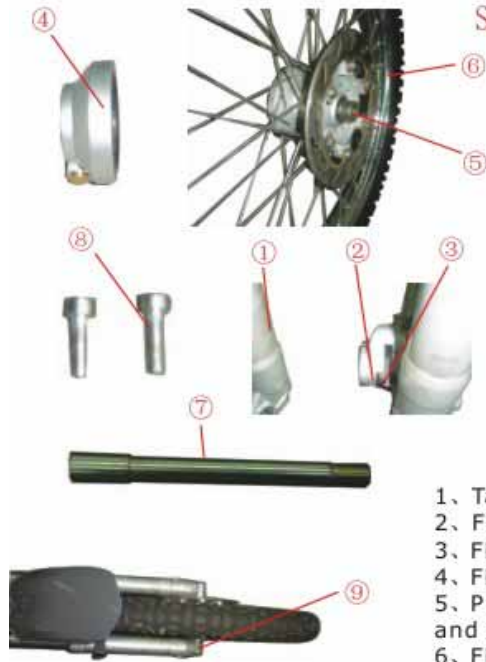

NO	Part Name	Spec.	Quantity	Memo.
①	Front fork		1	On motorcycle
②	Brake caliper		1	On motorcycle
③	Brake clip		1	On brake caliper
④	Calculator		1	On motorcycle
⑤	Bush		1	On motorcycle
⑥	Front wheel		1	On the rear left part of tray
⑦	Axle, front wheel		1	On front fork
⑧	Bolt, hexagon	M6×20	2	In accessory bag
⑨	B. Shock absorber		1	On motorcycle

1. Take ③ out;
2. Fix ⑤ in ⑥;
3. Fix ④ on side of ⑥;
4. Fix ⑥ on ①. Note: make sure brake disc brake is in ②;
5. Put ⑦ though ⑨, ④, ⑥ and ⑤, then fix and tighten it on the right side of ①;
6. Fix and tighten ⑧ on the lower end of ⑨.

Step eight: Assemblage of rear brake pedal



NO	Part Name	Spec.	Quantity	Memo.
①	Screw	M10×35	1	On motorcycle
②	Rear Brake Switch Spring		1	On motorcycle
③	Rear Brake Shoe Spring		1	On motorcycle

1. Tighten Fixture ①
2. Check ②、③. Firm Assemble , not allow to shed



Step nine:Assemblage of Battery

NO	Part Name	Spec.	Quantity	Memo.
①	Seat Screw		1	On Motorcycle
②	Seat		1	On Motorcycle
③	Right Body Cover, Screw		1	On Motorcycle
④	Frame Stand		1	On Motorcycle
⑤	Right Body		1	On Motorcycle
⑥	Nut		2	On Motorcycle
⑦	Battery Bracket		1	On Motorcycle
⑧	Battery		1	In accessories Bag
⑨	Cathode Line		1	On Motorcycle
⑩	Anode Line		1	On Motorcycle
⑪	Bolt	M6x20 M6x25	1	On Motorcycle
⑫	Bolt Side, Rear Armrest		1	On Motorcycle
⑬	Nut	M6	1	In accessories Bag

1. Spin Out 11 ,Take Down 12
2. Spin Out ① ,Take out ②
3. Spin Out ③ ,Take Down ⑤
4. Take Out ⑧ and According to the Battery Specification to maintenance
Spin Out ⑥ , Take Down ⑦ ,fix on ⑧
5. Make ⑨、⑩ to connect with the two Pole of ⑧
(Note: ⑨ connect with Cathode and ⑩ connect with Anode), then pull on the insulating Tape
6. Use ⑬ to fit in ⑦
7. Re-Cover ⑤ , Use ③ to fix ⑤ on ④
8. According to the disassembled Manner to re-assemble ②.
12. Use 13 to fix ②

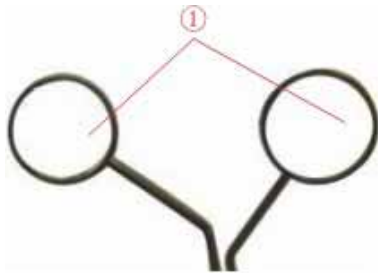

Step ten:Assemblage of rearview mirror

NO	Part Name	Spec.	Quantity	Memo.
①	Rearview mirror		1 assy	In accessory bag
②	Screw seat, L. handlebar lever		1	On handlebar
③	Screw seat, brake lever		1	On handlebar

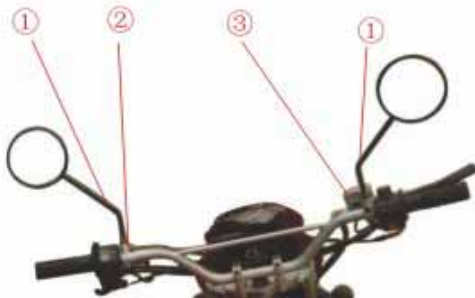

Step eleven: Assemblage of RR. L. Turnsignal Light



NO	Part Name	Spec.	Quantity	Memo.
①	Nut	M6	1	In accessory bag
②	Screw	M6×16	1	In accessory bag
③	Rear Fender		1	On motorcycle
④	RR.L. Turn-signal Light		1	On motorcycle

1. Fill ① into ③

2. Use ② fix 1 in ③

Step twelve: Assemblage of Rr. Footrest



NO	Part Name	Spec.	Quantity	Memo.
①	Bolt	M8×25	2	In accessory bag
②	Frame Stand		2	On motorcycle
③	Rear Footrest		2	On motorcycle

1. Use ① to fix ③ in ② (Note: the same way of Right Side and Left Side)